



C42EE342

E-MAJOR AB

PRODIS-GUT Certificate

**The article mentioned meets the test criteria of
Gemeinschaft umweltfreundlicher Teppichboden e.V.**

Short description of the textile floor covering

Type of production: pile carpet acc. EN 1307:2014 - tufted
Type of surface: loop pile - loop pile like - multicoloured plain
100% PA6
Type of backing: textile backing - woven - man-made fibres

Harmful substances

The bans on use and thresholds, if applicable, in particular for SVHCs, carriers, azo dyes, allergenic and carcinogenic dyes, heavy metals chlorophenols (e.g. PCP), biocidal substances, phthalates and other softeners, halogenised flame retardants and Sb_2O_3 as well as inorganic fibres specified in the GUT criteria have been met.

Formaldehyde

The ban on the use of adjuvants containing or splitting off formaldehyde have been met.
The formaldehyde emissions are $< 10 \mu\text{g}/\text{m}^3$.

VOC emissions

| Threshold in $\mu\text{g}/\text{m}^3$ | 3 days | 28 days |
|---------------------------------------|----------------|---------|
| TVOC (C_6-C_{16}): | 250 | 100 |
| VOC without NIK: | 100 | 50 |
| SVOC ($C_{16}-C_{23}$): | 30 | 30 |
| R-value: | 1,0 | 1 |
| HCHO: | 10 | 4 |
| carcinogenics: | not detectable | |
| benzene: | not detectable | |

The limit values for VOC emissions indicated alongside, determined in accordance with the test chamber process (ISO 16000-6 or EN 10580), have been met. The test was made 3 days, or, where required, 28 days after placement into the chamber.

The evaluation of the emissions and the calculation of the R value were based on the then current LCI list of the AgBB.

Odour

The product has passed the odour test with at least the grade 3.
A slight odour of low intensity is permissible in new merchandise.

Shares of recycled materials

The requirements regarding the content of contaminants and the emission behaviour apply unrestrictedly also to products whose manufacture included the use of recycled materials. The use of recycled raw materials (e.g. pile fibres) must be indicated when the manufacturer registers the article.

For a complete list of all limit values and test criteria see

www.gut-ev.de

Aachen, 13.03.2019



This certificate was issued electronically and requires no further signature

Gemeinschaft umweltfreundlicher Teppichboden e.V.,
D-52068 Aachen, Schönebergstrasse 2

PRODIS

**THE COMPREHENSIVE
EUROPEAN PRODUCT
INFORMATION SYSTEM FOR
TEXTILE FLOORCOVERINGS**

GUT Product Test Criteria and limit values

The GUT Signet can be granted only to members of Gemeinschaft umweltfreundlicher Teppichboden e.V.

(Only manufacturers of textile floorcoverings can become members)



The use of the substances listed below is either forbidden or GUT has specified limit values for the substances that must not be exceeded.

ORGANIC CARRIERS (DYEING ACCELERANTS)

GUT test procedure No. 1

There is a ban on the use of the carriers listed.

Di-, tri-, tetra-, penta- and hexachlorobenzenes; di-, tri-, tetra- and pentachlorotoluenes

AZODYES

GUT test procedure No. 2

There is a ban on the use of dyes and pigments which, under reductive conditions, release carcinogenic amines.

4-aminodiphenyl, benzidine, 4-chloro-o-toluidine, 2-naphthylamine, o-amino-azotoluene, 2-amino-4-nitrotoluene, p-chloroaniline, 2,4-diaminoanisole, 4,4'-diaminodiphenylmethane, 3,3'-dichlorobenzidine, 3,3'-dimethoxybenzidine, 3,3'-dimethylbenzidine, 3,3'-dimethyl-4,4'-diaminodiphenylmethane, p-cresidine, 4,4'-methylene-bis-(2-chloroaniline), 4,4'-oxydianiline, 4,4'-thiodianiline, o-toluidine, 2,4-diaminotoluene, 2,4,5-trimethylaniline, o-anisidine, p-amino-azobenzene*, 2,4-xylidine, 2,6-xylidine, 6-amino-2-ethoxynaphthalene**, 4-amino-3-fluorophenol**
(*not identifiable, **special procedure required)

DISPERSE DYES

GUT test procedure No. 3

There is a ban on the use of the dyes listed, which are classified as "allergising".

C.I. Disperse Blue 1, -3, -7, -26, -35, -102, -106 and -124, C.I. Disperse Orange 1, -3, -37/76, C.I. Disperse Red 1, -11 and -17, C.I. Disperse Yellow 1, -3, -9, -39 and -49

CARCINOGENIC DYES

GUT test procedure No. 4

There is a ban on the use of the dyes listed, which are classified as "carcinogenic".

C.I. Acid Red 26, C.I. Basic Red 9, C.I. Direct Red 28, C.I. Direct Blue 6, C.I. Disperse Blue 1, C.I. Disperse Yellow 3, C.I. Direct Black 38

HEAVY METALS

GUT test procedure No. 5

Dyes and pigments containing the listed heavy metals as ingredients of the dyeing component must not be used to dye the pile material. The limit value for the total heavy metal content of a fitted carpet is 100 mg/kg.

Pb (lead), Cd (cadmium), Hg (mercury), Cr (chromium total) or Cr(VI)

FLAME RETARDANTS

GUT test procedure No. 6

There is a ban on the use of the halogenous and phosphorous flame retardants listed.

PBB, TRIS, TEPA, SCCPs, PeBDE (pentabromodiphenylether)

ACTIVE BIOCIDAL SUBSTANCES

GUT test procedure No. 7

For the biocides listed that may be contained as active substances in respective formulations there is either a ban on their use or a limit value was specified for the respective active substance or group of active substances.

- 1) There is a ban on the use of products containing **TBT**.
- 2) The limit value for the **chlorophenols**, pentachlorophenol and tetrachlorophenol (PCP and TeCP), is 0.1 mg/kg.
- 3) For **orthophenylphenol** (OPP), there is a limit value of 1 mg/kg.
- 4) For the **chlororganic pesticides** listed, there is a limit value of 0.04 mg/kg for each individual substance and of 1 mg/kg for the sum of all components, respectively.
o,p' and p,p' -DDE, -DDD and -DDT, α , β , δ , ϵ -hexachlorocyclohexane, aldrine, dieldrine, endrine, heptachlor, heptachloroepoxide, hexachlorobenzene, lindane, methoxychlor, mirex, toxaphene, * α - and β -endosulphane
- 5) For the **phosphororganic pesticides** listed, there is a limit value of 0.04 mg/kg for each individual substance and of 1 mg/kg for the sum of all components, respectively.
Diazinon, dichlorofenthion, dichlorophos**, malathion**, parathion-ethyl, parathion-methyl*, trifluralin (*special procedures required, **other identification limits).
- 6) For the **herbicides**, 2,4,5-T and 2,4-D, there is a limit value of 0.04 mg/kg for each individual substance and of 1 mg/kg for the sum of all components, respectively.
- 7) Except for permethrine, there is a ban on the use of all **pyrethroids** for the protection of wool against moths and beetles.
- 8) As moth- and beetle-proofing agent for the sole finishing of woollen fitted carpets, **permethrine** may be used up to a maximum limit of 210 mg/kg. Application must be conducted in compliance with a prescribed procedure.

EMISSIONS FROM TEXTILE FLOORCOVERINGS

GUT test procedure No. 8

Volatile organic components from textile floorcoverings are determined in compliance with the test-chamber process. The following limit values are specified for the components listed.

| | | |
|--|------------------------------|---|
| TVOC | 300 $\mu\text{g}/\text{m}^3$ | Test chamber method (EN 13419; 1+2; ISO 16000). The test is performed 72h after $t = 0$. For calculation and evaluation of the R-value, the actual LCI-Value List as published by AgBB* is used. |
| VOC without LCI | 100 $\mu\text{g}/\text{m}^3$ | |
| R-Value | ≤ 1 | |
| SVOC (C ₁₆ to C ₂₂) | 30 $\mu\text{g}/\text{m}^3$ | |
| Cancerogenic Substances (EU-list Class 1 a. 2) | n.n. | |

* Ausschuss zur gesundheitlichen Bewertung von Baumaterialien

ODOUR

GUT test procedure No. 9

The material tested should only have the low-intensity odour typical of a new product.

The test mark following appraisal by a team of 7 persons must be a value < 4 .

REQUIREMENTS ON LATICES

GUT test procedure No. 10

The latices used for coating must meet the following requirements on the residual monomer content.

For the individual substances styrene and 4-PCH, the limit value is 200 mg/kg of latex, and for ethylbenzene and 4-VCH, the limit value for each is 50 mg/kg of latex.

The limit value of the sum for all 4 components is 400 mg/kg of latex.

For the manufacture of foam coatings, there is a ban on the use of the vulcanisation accelerator Zn-diethyldithiocarbamate (ZDEC).



DECLARATION OF PERFORMANCE

DOP: 1011#IE0ACL

1. Unique identification code of the product-type:

1011#IE0ACL

2. Type, batch or serial number or any other element allowing identification of the construction product as required pursuant to Article 11(4):

E-MAJOR AB - Textile floor covering - pile carpet acc. EN 1307:2014

3. Intended use or uses of the construction product, in accordance with the applicable harmonised technical specification, as foreseen by the manufacturer:

For use as floor covering in buildings (see EN 14041) according to the manufacturer's specifications.

4. Name, registered trade name or registered trade mark and contact address of the manufacturer as required pursuant to Article 11(5):

Balta Industries NV/Division ITC - Kanegemstraat 15 - B - 8700 Tielt



5. Where applicable, name and contact address of the authorised representative whose mandate covers the tasks specified in Article 12(2):

6. System or systems of assessment and verification of constancy of performance of the construction product as set out in Annex V:

System 3

7. In case of the declaration of performance concerning a construction product covered by a harmonised standard: Name of the notified test laboratory, that has issued the certificate of conformity of the factory production control, inspection reports and calculation reports (if relevant).

CRET; Centre de recherches et d'etudes techniques du tapis Rue du vert bois, Zone industrielle, P.O. Box 30 F - 59531 Neuville-en-Ferrain Cedex

Notified Body





2013/084

certificate of constancy of performance

8. In case of the declaration of performance concerning a construction product for which a European Technical Assessment has been issued:

not applicable

9. Declared performance

| Essential characteristics | Performance | Harmonised technical specification |
|-----------------------------------|---|------------------------------------|
| Reaction to fire |  | EN 14041:2008-05 |
| Content of Pentachlorophenol |  | EN 14041:2008-05 |
| Formaldehyd Emissions |  | EN 14041:2008-05 |
| Slip resistance |  | EN 14041:2008-05 |
| Electrical behavior (dissipative) | NPD | EN 14041:2008-05 |
| Electrical behavior (conductive) | NPD | EN 14041:2008-05 |
| Electrical behavior (antistatic) | NPD | EN 14041:2008-05 |
| Thermal conductivity [W/mK] | NPD | EN 14041:2008-05 |
| Water-tightness | NPD | EN 14041:2008-05 |

10. The performance of the product identified above is in conformity with the set of declared performance/s.

This declaration of performance is issued, in accordance with Regulation (EU) No 305/2011, under the sole responsibility of the manufacturer Signed for and on behalf of the manufacturer by:

Luc Jongbloet, Business unit manager ITC-Balta Carpets - Balta tiles
(name and function)

18.03.2019, Tielt
(place and date of issue)

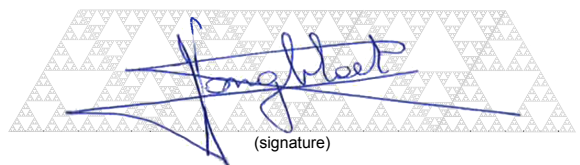
(signature)

TFI Report 480556-01

Sound Absorption Impact Sound Insulation

Customer

BALTA Industries N.V.
Division ITC
Kanegemstraat 15
8700 Tielt
BELGIUM

Product

textile floor covering
E Major AB

This report includes 2 pages and 2 annex(es)

Responsible at TFI

-Senior Engineer-
Dr.-Ing. Heike Kempf
Tel: +49 241 9679 171
h.kempf@tfi-online.de

Aachen, 18.04.2018

Dr. Alexander Siebel
- Head of the testing laboratory -

The present document is provided with an advanced electronic signature



This report only applies to the tested samples and has been established to the best of our knowledge. Only the entire report shall be reproduced. Under no circumstances, extracts shall be used. Furthermore, we apply the "General Terms and Conditions for the Execution of Contracts" of the TFI Aachen GmbH, also with regard to the order execution.

1 Transaction

| | |
|---------------------|--|
| Test order | sound absorption according to EN ISO 354 sound insulation according to EN ISO 10140 |
| Order date | 22.03.2018 |
| Your reference | D. Devos |
| Product designation | E Major AB |
| TFI sample number | 18-03-0173 |

2 Product Specification

| | |
|---------------------|------------------------------|
| Type of manufacture | tufted |
| Type of surface | loop pile |
| Backing | woven textile backing* |
| Pattern | tonal effect without pattern |
| Colour | grey, black |

View



| | |
|----------------------------------|-----------|
| Thickness [mm] | 5.8* |
| Area density [g/m ²] | 1950* |
| Type of delivery | broadloom |

*customer information

3 Results

| | |
|-------------------------|-----------------------|
| Sound absorption | $\alpha_w = 0,15$ (H) |
| Impact sound insulation | $\Delta L_w = 24$ dB |

4 Annexes

| | |
|-------------------------|---------------------------|
| Sound absorption | SA 480556-01 ^a |
| Impact sound insulation | TS 480556-01 ^a |

The annexes marked ^a are based on tests accredited in accordance with EN ISO/IEC 17025.

Annex SA - Sound Absorption Coefficient

1 Transaction

| | |
|---------------------|------------|
| Product designation | E Major AB |
| TFI sample number | 18-03-0173 |
| Testing period | 13.04.2018 |

2 Test Method / Requirements

| | |
|-----------------------------|--|
| EN ISO 354:2003 | Measurement of sound absorption in a reverberation room |
| EN ISO 11654:1997 | Sound absorbers for use in buildings – Rating of sound absorption |
| Deviation from the standard | None |

3 Remarks

None

4 Measuring Operation

| | |
|-----------------|---|
| Test noise: | broadband pink noise |
| Receive filter: | third octave band filter |
| Measurement: | 2 loudspeaker positions 6 microphone positions |

5 Laboratories

| | |
|----------------|---|
| Test rooms: | laboratory of the TFI Aachen GmbH, Hauptstr. 133, 52477 Alsdorf, Germany |
| Test method: | reverberation room method |
| Volume: | 211 m ³ |
| Total surface: | 213 m ² |
| Floor plan: | trapezoidal |
| Reflectors: | 6 aluminium plates 1.0 m x 2.0 m 7 plywood boards 1.5 m x 1.3 m 1 aluminium plate 1.8 m x 0.9 m |

6 Measuring Devices

| | |
|---------------------|------------------------------|
| Real time analyser: | Norsonic Nor140, SN: 1406926 |
| Microphone: | Norsonic Type 1209/21134 |
| Loudspeaker: | 2 dodecahedrons |

7 Evaluation

The decay curves are determined using the interrupted noise method. Several decay curves measured at one microphone and/or loudspeaker position are averaged in order to reach a sufficient reproducibility. The reverberation time of the room is expressed by the arithmetic mean derived from the total number of all reverberation time measurements in each frequency band.

The equivalent sound absorption area of the test specimen A_T is calculated as the difference between the equivalent sound absorption area of the reverberation room with test specimen A_2 and the equivalent sound absorption area of the empty reverberation room A_1 without test specimen.

The equivalent sound absorption coefficient α_s describes the ratio of the equivalent sound absorption area A_T of a test specimen divided by the area of the test specimen.

The evaluated sound absorption coefficient α_w is a single-number frequency-independent value which equals the value of the reference curve at 500 Hz after shifting it.

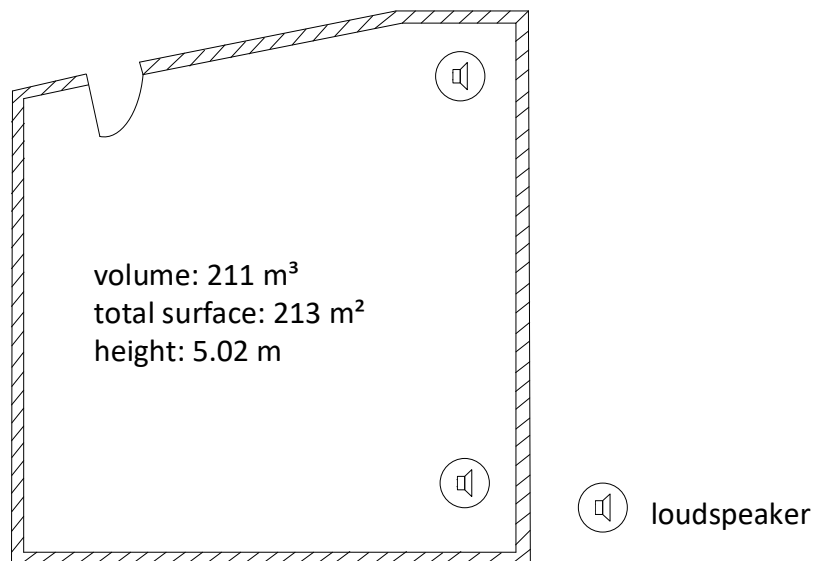

Drawing reverberation room

Measurement of sound absorption coefficient in a reverberation room

Annex SA – Sound absorption

Page 1 of 2

TFI sample no.: 18-03-0173

Testing period: 13.04.2018

Construction: -
(from top to bottom)

Product name: E Major AB

Reverberation room / without

Relative humidity: 42,4 %
Temperature: 20,1 °C
Barometric pressure: 98,8 kPa

Reverberation room / with sample

Relative humidity: 42,4 %
Temperature: 20,1 °C
Barometric pressure: 98,8 kPa

Surface area: 12,16 m²
Room volume: 211,0 m³
Total room area St: 213 m²

| Frequency f [Hz] | α_p Oktave |
|------------------------|----------------------|
| 100 125 160 | 0,00 |
| 200 250 315 | 0,05 |
| 400 500 630 | 0,05 |
| 800 1000 1250 | 0,15 |
| 1600 2000 2500 | 0,40 |
| 3150 4000 5000 | 0,45 |

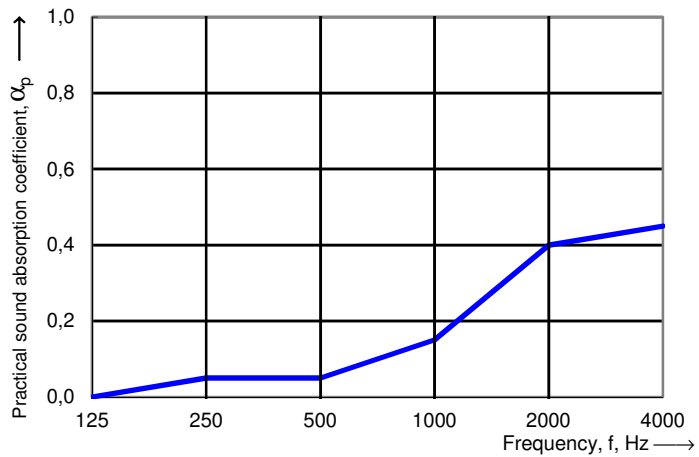

Weighted sound absorption coefficient according to ISO 11654

$\alpha_w = 0,15$ (H)



Sound absorption according ISO 354

SA 480556-01

Measurement of sound absorption coefficient in a reverberation room

Annex SA – Sound absorption

Page 2 of 2

Weighted sound absorption coefficient according to ISO 11654

$$\alpha_w = 0,15 \text{ (H)}$$

Surface area: 12,16 m²Room volume: 211,0 m³Total room area St: 213,0 m²

| Frequency [Hz] | α_p | α_s | A [m ²] | T1 [s] | T2 [s] |
|-------------------|------------|------------|------------------------|-----------|-----------|
| 50 | | 0,00 | 0,0 | 10,03 | 10,10 |
| 63 | 0,00 | 0,00 | 0,0 | 8,41 | 8,43 |
| 80 | | 0,02 | 0,3 | 10,47 | 9,70 |
| 100 | | 0,01 | 0,2 | 10,44 | 9,97 |
| 125 | 0,00 | 0,03 | 0,3 | 6,89 | 6,45 |
| 160 | | 0,02 | 0,2 | 6,41 | 6,18 |
| 200 | | 0,02 | 0,2 | 6,64 | 6,35 |
| 250 | 0,05 | 0,02 | 0,3 | 6,53 | 6,21 |
| 315 | | 0,05 | 0,7 | 6,05 | 5,41 |
| 400 | | 0,06 | 0,7 | 5,74 | 5,16 |
| 500 | 0,05 | 0,07 | 0,9 | 6,07 | 5,27 |
| 630 | | 0,09 | 1,1 | 5,90 | 4,96 |
| 800 | | 0,12 | 1,4 | 5,56 | 4,52 |
| 1000 | 0,15 | 0,17 | 2,1 | 5,38 | 4,05 |
| 1250 | | 0,23 | 2,8 | 5,39 | 3,72 |
| 1600 | | 0,33 | 4,0 | 5,05 | 3,16 |
| 2000 | 0,40 | 0,40 | 4,9 | 4,65 | 2,79 |
| 2500 | | 0,44 | 5,4 | 4,05 | 2,48 |
| 3150 | | 0,42 | 5,1 | 3,28 | 2,20 |
| 4000 | 0,45 | 0,46 | 5,7 | 2,68 | 1,85 |
| 5000 | | 0,46 | 5,6 | 2,00 | 1,51 |

Reverberation room / without sample:

Relative humidity: 42,4 %

Temperature: 20,1 °C

Barometric pressure: 98,8 kPa

Reverberation room / with sample:

Relative humidity: 42,4 %

Temperature: 20,1 °C

Barometric pressure: 98,8 kPa

TFI sample number:

18-03-0173



Annex TS - Impact Sound Insulation

1 Transaction

| | |
|---------------------|------------|
| Product designation | E Major AB |
| TFI sample number | 18-03-0173 |
| Testing period | 17.04.2018 |

2 Test Method / Requirements

| | |
|---------------------|--|
| EN ISO 10140-1:2014 | Acoustics - Laboratory measurement of sound insulation of building elements - Part 1: Application rules for certain products |
| EN ISO 10140-2:2010 | Acoustics - Laboratory measurement of sound insulation of building elements - Part 2: Measurement of airborne sound insulation |
| EN ISO 10140-3:2015 | Acoustics - Laboratory measurement of sound insulation of building elements - Part 3: Measurement of impact sound reduction |
| EN ISO 10140-4:2010 | Acoustics - Laboratory measurement of sound insulation of building elements - Part 4: Measurement procedures and requirements |
| EN ISO 10140-5:2014 | Acoustics - Laboratory measurement of sound insulation of building elements - Part 5: Requirements for test facilities and equipment |
| EN ISO 717-1:2013 | Acoustics - Rating of sound insulation in buildings and of building elements - Part 1: Airborne sound insulation |
| EN ISO 717-2:2013 | Acoustics - Rating of sound insulation in buildings and of building elements - Part 2: Impact sound reduction |

3 Remarks

None

4 Measuring Operation

| | |
|---|---|
| Measurement of the impact sound pressure level: | Using with 4 tapping machine position. (The single results of the one-third-octave-bands were averaged on an energy basis) |
| Test surface: | ~1m ² |
| Category: | I |
| Connection with the floor: | loose laid |
| Damage to the sample: | None |

5 Laboratories

| | |
|------------------------|--|
| Test rooms: | Laboratories of the TFI Aachen GmbH, Hauptstrasse 133, 52477 Alsdorf, Germany |
| Sending room (1.04): | $V = 52.1 \text{ m}^3$ (with diffusers) |
| Receiving room (0.01): | $4.05 \text{ m} \times 3.95 \text{ m} \times 3.33 \text{ m} + 2.00 \text{ m} \times 0.98 \text{ m} \times 0.18 \text{ m}$; $V = 53.6 \text{ m}^3$ (cuboid room, with diffusers) |
| Reference floor: | $4.27 \text{ m} \times 4.46 \text{ m}$; $S = 19.04 \text{ m}^2$ 14 cm concrete slab floor with an area-related mass of $m' \sim 322 \text{ kg/m}^2$ |
| Flanking walls: | Lime sand brick walls with light wall facings (facing shell $d = 12 \text{ cm}$) with an average area-related mass of $m' \sim 330 \text{ kg/m}^2$ |

6 Measuring Devices

| | |
|---------------------|--|
| Real time analyser: | Norsonic Nor140, SN: 1406927 Norsonic Nor140, SN: 1406926 |
| Microphone: | Norsonic Type 1209/21135 Norsonic Type 1209/21134 |
| Tapping machine: | NORSONIC, Type 211, SN: 502 (standard tapping machine with 3 feet and 5 hammers according to ISO 10140) |

7 Evaluation

The impact sound pressure level generated by the standard tapping machine is measured in the receiving room under a bare heavy floor with and without a floor covering. The impact sound reduction is determined on the basis of the measured values as follows:

$$\Delta L = L_{n,0} - L_n \text{ (dB)}$$

$L_{n,0}$ Impact sound pressure level without a floor covering (dB)

L_n Impact sound pressure level with a floor covering (dB)

For the evaluation of the weighted reduction in impact sound pressure level ΔL_w , the relevant reference curve is shifted in increments of 1 dB towards the measured curve until the sum of unfavourable deviations is as large as possible, but not more than 32 dB.

The linear impact sound level ΔL_{lin} is determined according to the following equation:

$$\Delta L_{lin} = L_{n,r,0,w} + C_{l,r,0} - (L_{n,r,w} + C_{l,r}) = \Delta L_w + C_{l,\Delta}$$

| | |
|---------------|---|
| $L_{n,r,w}$ | is the calculated weighted normalized impact sound pressure level of the reference floor with the floor covering under test |
| $L_{n,r,0,w}$ | 78 dB, calculated from $L_{n,r,0}$ according to Section 4.3.1 of DIN EN ISO 717-2: 2013 |
| $C_{l,r}$ | Spectrum adaptation term for the reference floor with the floor covering to be tested |
| $C_{l,r,0}$ | -11 dB, spectrum adaptation term for the reference floor with $L_{n,r,0}$ determined according to Annex A, Section A.2.1 of DIN EN ISO 717-2:2013 |

8 Note

The results are based on measurements performed under laboratory conditions with artificial excitation (standard procedure). The test results are applicable in due consideration of the national provisions and the local circumstances and/or constructions.

Impact sound insulation according ISO 10140-1

TS 480556-01

Laboratory measurements of the reduction of transmitted impact noise by floor coverings on a heavyweight reference floor

Annex TS – Impact sound insulation

Page 1 of 2

TFI sample number: 18-03-0173
 Product name: E Major AB

Testing period: 17.04.2018

Installed by: TFI

Construction:
 (from top to bottom) -

Receiving room:

Volume: 53,6 m³
 Air temperature: 20,8 °C
 Relative air humidity: 65,0 %
 Static pressure: 100,7 kPa

Source room:

Volume: 52,1 m³
 Air temperature: 21,5 °C
 Relative air humidity: 45,5 %
 Type of reference floor: Heavyweight

| Frequency f [Hz] | L _{n,0} 1/3 oct. [dB] | ΔL 1/3 oct. [dB] |
|------------------------|--------------------------------------|------------------------|
| 50 | 60,6 | 2,8 |
| 63 | 61,7 | 0,8 |
| 80 | 59,8 | 1,7 |
| 100 | 60,4 | 3,0 |
| 125 | 65,2 | 4,3 |
| 160 | 60,4 | 4,6 |
| 200 | 62,9 | 7,0 |
| 250 | 66,9 | 10,3 |
| 315 | 64,1 | 14,0 |
| 400 | 64,6 | 18,2 |
| 500 | 64,0 | 22,7 |
| 630 | 64,7 | 26,7 |
| 800 | 66,4 | 32,7 |
| 1000 | 66,6 | 40,8 |
| 1250 | 67,7 | 46,2 |
| 1600 | 68,3 | 49,3 |
| 2000 | 68,0 | 52,5 |
| 2500 | 67,7 | 57,6 |
| 3150 | 68,4 | 58,2 |
| 4000 | 67,0 | 56,8 |
| 5000 | 63,6 | 53,1 |

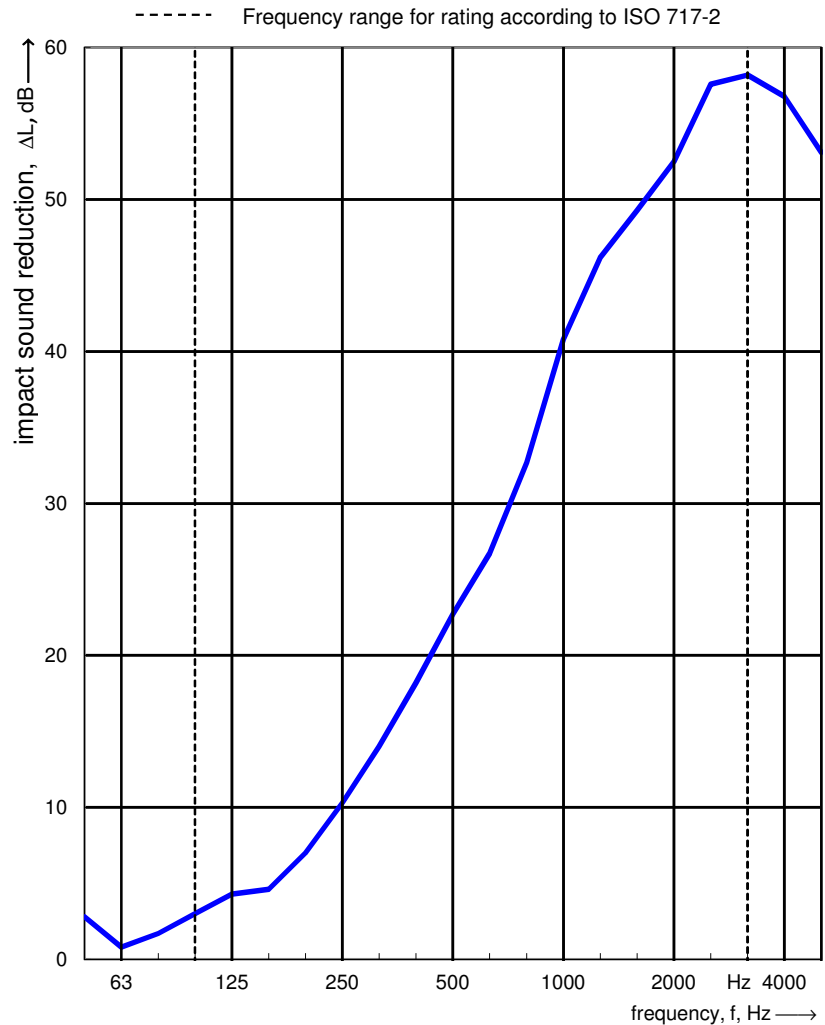

Evaluation according to ISO 717-2

ΔL_w = 24 dB

C_{l,Δ} = -12 dB

C_{l,r} = 1 dB

The results are based on measurements, which were performed under laboratory conditions with artificial excitation (standard procedure).



Impact sound insulation according ISO 10140-1

TS 480556-01

Laboratory measurements of the reduction of transmitted impact noise by floor coverings on a heavyweight reference floor

Annex TS – Impact sound insulation

Page 2 of 2

Evaluation according to ISO 717-2

$\Delta L_w = 24$ dB

$C_{i,\Delta} = -12$ dB

$C_{i,r} = 1$ dB

The results are based on measurements, which were performed under laboratory conditions with artificial excitation (standard procedure).

Weighted normalized impact sound pressure level $L_{n,0,w} = 74$ dB

Weighted normalized impact sound pressure level $L_{n,w} = 49$ dB

Weighted normalized impact sound pressure level $L_{n,r,w} = 54$ dB

| Frequency [Hz] | ΔL [dB] | $L_{n,0}$ [dB] | L_n [dB] | $L_{n,r}$ [dB] |
|-------------------|--------------------|-------------------|---------------|-------------------|
| 50 | 2,8 | 60,6 | 57,8 | |
| 63 | 0,8 | 61,7 | 60,9 | |
| 80 | 1,7 | 59,8 | 58,1 | |
| 100 | 3,0 | 60,4 | 57,4 | 64,0 |
| 125 | 4,3 | 65,2 | 60,9 | 63,2 |
| 160 | 4,6 | 60,4 | 55,8 | 63,4 |
| 200 | 7,0 | 62,9 | 55,9 | 61,5 |
| 250 | 10,3 | 66,9 | 56,6 | 58,7 |
| 315 | 14,0 | 64,1 | 50,1 | 55,5 |
| 400 | 18,2 | 64,6 | 46,4 | 51,8 |
| 500 | 22,7 | 64,0 | 41,3 | 47,8 |
| 630 | 26,7 | 64,7 | 38,0 | 44,3 |
| 800 | 32,7 | 66,4 | 33,7 | 38,8 |
| 1000 | 40,8 | 66,6 | 25,8 | 31,2 |
| 1250 | 46,2 | 67,7 | 21,5 | 25,8 |
| 1600 | 49,3 | 68,3 | 19,0 | 22,7 |
| 2000 | 52,5 | 68,0 | 15,5 | 19,5 |
| 2500 | 57,6 | 67,7 | 10,1 | 14,4 |
| 3150 | 58,2 | 68,4 | 10,2 | 13,8 |
| 4000 | 56,8 | 67,0 | 10,2 | |
| 5000 | 53,1 | 63,6 | 10,5 | |

Receiving room:

Volumen: 53,6 m³

Air temperature: 20,8 °C

Relative air humidity: 65,00 %

Static pressure: 100,7 kPa

Source room:

Volumen: 52,1 m³

Air temperature: 21,5 °C

Relative air humidity: 45,5 %

Type of reference floor: Heavyweight



TFI sample number:

18-03-0173



REACTION TO FIRE CLASSIFICATION REPORT
N° 2013/084-1

(English report of classification report RC 2013/084)

According to EN 13501-1 (2007) + A1 (2013)

Notification by the French Government to the European Commission
under n° NB 2401
Regulation (UE) n° 305/2011

Sponsor : BALTA INDUSTRIES N.V / DIVISION I.T.C
Kanegemstraat 15
B 8700 TIELT
BELGIUM

Product name : Products group Tufted carpet 100 % polyamide
(Updated)

Description : Textile floor coverings (EN 1307 family)
(see detailed description in paragraph 2)

Date of issue : 16/08/2018

The indicated classification does not prejudice the conformity of marketed materials with the samples submitted to the tests and under no circumstances, this document should not be considered as type approval or certification of the product in the sense of the L 115-27 article of the consumption's code of the law dated June 3rd 1994.

*The reproduction of this classification report is only authorised in its integral form.
It comprises 5 pages*

1. Introduction

This classification report defines the classification assigned to the above-mentioned product (s) in accordance with the procedures given in the NF EN 13501-1 standard: September 2007 & A1 (2013).

2. Details of classified product**2.1. Product standard**

NF EN 14041 (2005):“ Resilient, textile and laminate floor coverings - Essential characteristics”.

2.2. Product description

Tufted pile carpet 100% polyamide on woven polypropylene backing (EN 1307 family).

Tested loose laid over a fibre-cement board classified A1_n or A2_n with a density (1800 ± 200) kg/m³ and thickness (8 ± 2) mm.

Use surface: 100 % polyamide.

Nominal mass per unit area : 1350 to 2400 g/m²

Nominal effective pile thickness : 2,1 to 5,9 mm

3. Test reports and tests results in support of this classification**3.1. Tests reports**

| Name of laboratory | Name of sponsor | Test report N° | Test method |
|--------------------|---|---|---------------|
| C.R.E.T. | BALTA INDUSTRIES N.V / DIVISION I.T.C Kanegemstraat 15 B 8700 TIELT BELGIUM | RL 2017/114 + classification report 2017/032-1 (21/02/2017) | EN ISO 9239-1 |

| Name of laboratory | Name of sponsor | Test report N° | Test method |
|--------------------|---|---|---------------|
| C.R.E.T. | BALTA INDUSTRIES N.V / DIVISION I.T.C Kanegemstraat 15 B 8700 TIELT BELGIUM | RL 2013/392 + classification report 2013/076-1 (28/11/2013) | EN ISO 9239-1 |

| Name of laboratory | Name of sponsor | Test report N° | Test method |
|------------------------|---|-------------------------|---------------|
| CENTEXBEL (NB 0493) | BALTA INDUSTRIES N.V / DIVISION I.T.C Kanegemstraat 15 B 8700 TIELT BELGIUM | N° 80368/C (23-06-2011) | EN ISO 9239-1 |

3.2. Tests results

Classes of reaction to fire for textile floor coverings, classified without further testing.

| | |
|----------------|---|
| Test method | The floorings « TRIANON AB / TN + dessin AB » - « MASTER AB - MAESTRO AB » - « PROVIDER AB » meet the requirements of table 2 of the standard EN 14041 and are classified without further testing (CWFT) |
| EN ISO 11925-2 | Classification E_n |

| Test method | Product | Number of tests | Parameters | Results |
|---------------|--|-----------------|---|------------------------------------|
| | | | | Continuous parameters : mean value |
| EN ISO 9239-1 | TRIANON AB / TN + dessin AB (classification report CRET 2017/032-1) | 3 | Critical heat flux (kW/m ²) | ≥ 4,5 |
| | | | Smoke (% X min) | ≤ 750 |

| Test method | Product | Number of tests | Parameters | Results |
|---------------|---|-----------------|---|------------------------------------|
| | | | | Continuous parameters : mean value |
| EN ISO 9239-1 | MASTER AB – MAESTRO AB (classification report CRET 2012/076-1) | 3 | Critical heat flux (kW/m ²) | ≥ 4,5 |
| | | | Smoke (% X min) | ≤ 750 |

| Test method | Product | Number of tests | Parameters | Results |
|---------------|--|-----------------|---|------------------------------------|
| | | | | Continuous parameters : mean value |
| EN ISO 9239-1 | PROVIDER AB (Test report CENTEXBEL 80368/C) | 3 | Critical heat flux (kW/m ²) | ≥ 4,5 |
| | | | Smoke (% X min) | ≤ 750 |

4. Classification and field of application

4.1. Reference of classification

This classification has been carried out in accordance with EN 13501-1 :2007 & A1 (2013).

4.2. Classification

| Fire behaviour | | Smoke production |
|-----------------|---|------------------|
| C _{fl} | - | s1 |

Classification : C_{fl} – s1

4.3. Field of application

This classification is valid for the following end use applications :

Loose laid over fibre-cement A2_{fl} or A1_{fl} class with a density ≥ 1350 kg/m³.

This classification is valid for the following product parameters :

- A nominal mass per unit area of: 1350 to 2400 g/m²
- A nominal effective pile thickness of : 2,1 to 5,9 mm

The classification of the product family is valid for the following trademarks :

AKROPOLIS AB
AKTUA AB
AKZENTO AB
AMADEO AB
ARISTOCRAT AB
ART DECO AB
ARTE AB / AT + dessin AB
ARTO AB
ARUNDEL AB / AD + dessin AB
BAROQUE AB
BELGRAVIA AB
BELLEVUE AB
BELVEDERE AB
BIRKDALE AB
BRIDGEFORD AB
CAVALLI AB
CHABLIS AB
CHAMBORD AB
CHIC AB
COLUMN AB
CONSUL AB / CS + dessin AB
CORONET AB
CRYSTAL PALACE AB
E-GRID AB
E-MAJOR AB
E-ROCK AB
FEMI AB
FLOXIMO AB
FORTISSIMO AB
GALLERIA AB
GRANATA AB
HERCULES AB
HERITAGE NEW AB
KREA AB
MAESTRO AB
MARQUIS AB / MQ + dessin AB
MASTER AB
MONOGRAM AB / MG + dessin AB
PAGEANT AB
PALACE NEW AB
PODIUM AB
PROGRESSA AB / PG + dessin AB
PROJECTA AB / PJ + dessin AB
PROMENADE AB / PM + dessin AB
PROMINENT AB
PROSPECTA (NEW) AB / PP (NEW) + dessin AB
PROVIDER AB / PV + dessin AB
RICHELIEU AB
RIVELLO AB / RV + dessin AB (= LOVE VINTAGE COLLECTION)
ROCCA AB
ROCKET AB
SHERINGTON AB
SIRIO AB
SPIRIT AB

SPLENDID AB
SPONTINI AB
TOSCANA AB
TREVISO AB
TRIANON AB / TN + dessin AB
VIENNA AB

5. Limitations

This classification document does not represent type approval or certification of the product.

“The classification assigned to the product in this report is appropriate to a declaration of conformity by the manufacturer within the context of system 3 attestation of conformity and CE marking under the Construction Products Directive.

The manufacturer has made a declaration, which is held on file. This confirms that the products design requires no specific processes, procedures or stages (no addition of flame-retardants, limitation of organic content, or addition of fillers) that are aimed at enhancing the fire performance in order to obtain the classification achieved. As a consequence the manufacturer has concluded that system 3 attestation is appropriate.

The test laboratory has, therefore, played no part in sampling the product for the test, although it holds appropriate references, supplied by the manufacturer, to provide for traceability of the samples tested.”

For the SARL C.R.E.T.
The Technical Director
Marc WELCOMME



End of the classification report